

5/11  
7.70  
WP

1-A timber beam is simply supported and loaded as shown below. Determine the maximum bending stress due to a uniformly distributed load of 5 kN/m.

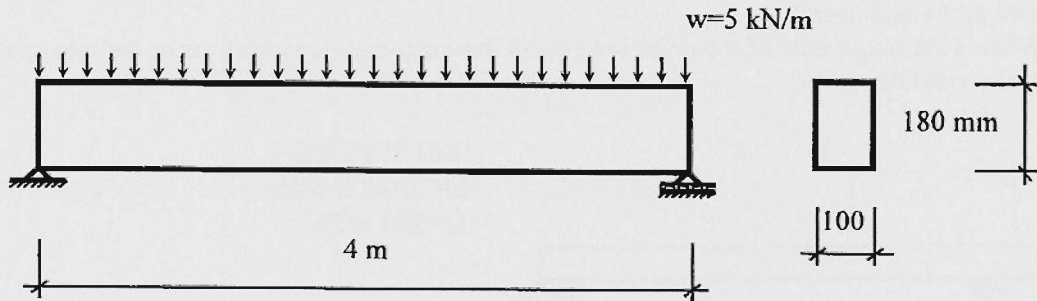

2-A W840x329 steel beam is simply supported and loaded as shown below. Determine the maximum tensile and compressive bending stresses for  $P = 500 \text{ kN}$  and  $w = 180 \text{ kN/m}$ .

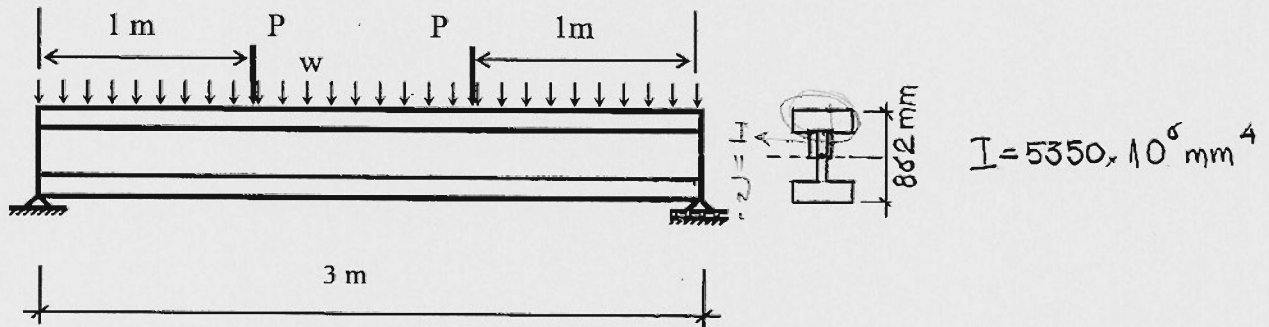

3-A built-up section made up of plywood and sawn timber sections are glued together as shown. The beam is used to span a 4 m opening with a uniformly distributed load of 4.0 kN/m. Determine the highest tensile stress and the highest compressive stress. Comment on the efficiency of the cross-sectional shape and suggest how it may be improved.

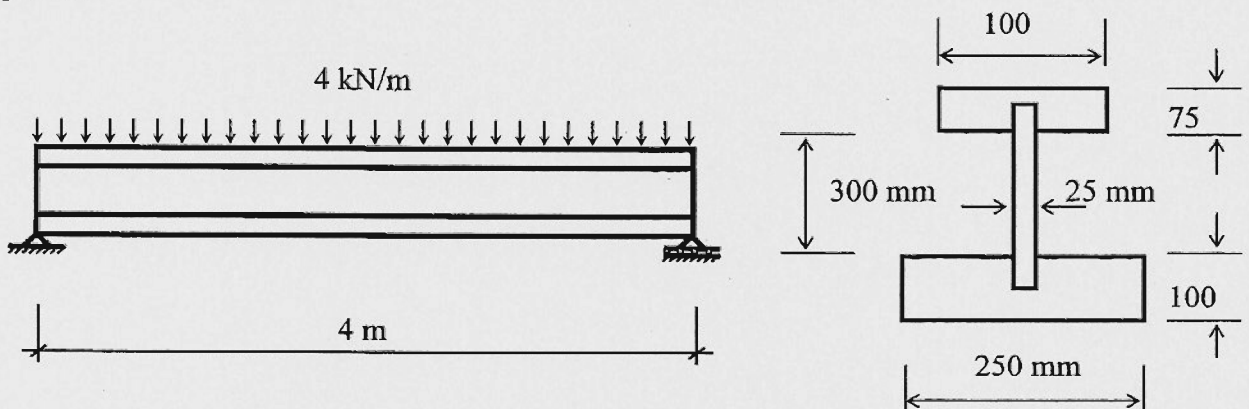

4- A strain indicator is attached to the bottom of a beam consisting of a steel hollow structural section as shown below.

- (a) If the tensile strain reading at B is equal to  $0.6 \times 10^{-3}$  mm/mm, what is the magnitude of the point load at the mid-span?
- (b) What is the magnitude of the point load when the maximum tensile stress at the mid-span is equal to the yielding stress?

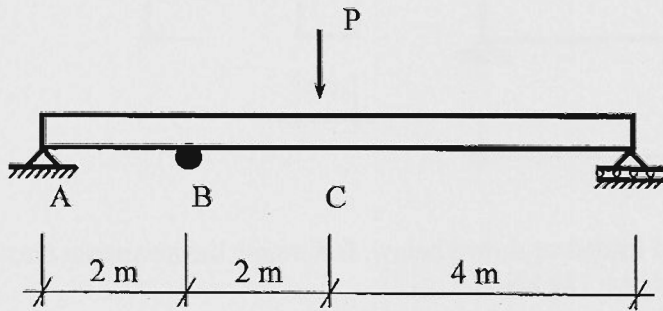

HSS 89x89x6.4  
E=200000 MPa  
 $f_y=350$  MPa



5/5

1.

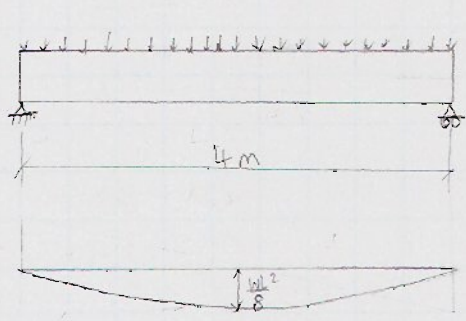

$w = 5 \text{ kN/m}$

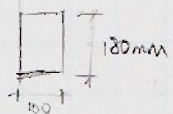

$$M = \frac{wL^2}{8}$$

$$M = \frac{5 \text{ kN/m} \times (4\text{m})^2}{8}$$

$$= 10 \text{ kN}\cdot\text{m} = 10 \times 10^6 \text{ N}\cdot\text{mm}$$

$$\sigma_{\text{max}} = \frac{M_{\text{max}}}{I}$$

$$= \frac{(10 \times 10^6 \text{ N}\cdot\text{mm}) \times 90 \text{ mm}}{\frac{100 \times 180^3}{12}}$$

$$\therefore \sigma_{\text{max}} = 18.52 \text{ MPa}$$

2.

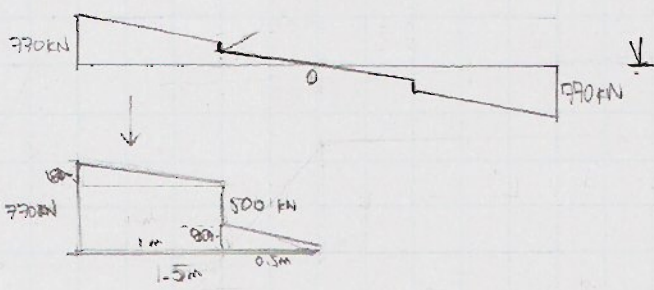
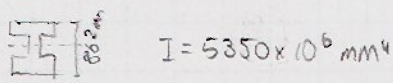
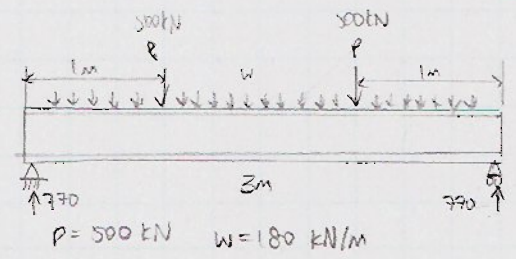

$M = \text{Area under V diagram (max at centre)}$

$$= \frac{1}{2}(180)(1) + \frac{1}{2}(0.5)(90) + (1)(590)$$

$$= 702.5 \text{ kN}\cdot\text{m}$$

$$= 702.5 \times 10^6 \text{ N}\cdot\text{mm}$$

$$\sigma_{\text{max}} = \frac{M_{\text{max}}}{I}$$

$$= \frac{(702.5 \times 10^6) \times \frac{262}{2}}{5350 \times 10^6}$$

$$= 56.6 \text{ MPa}$$

Since the section is symmetrical,  
The highest compression and tension stress  
is 56.6 MPa

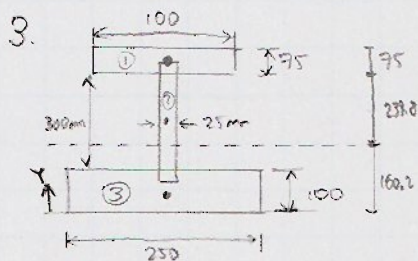

Section	A ( $\times 10^3 \text{ mm}^2$ )	$\bar{y}$ (mm)	$A\bar{y}$ ( $\times 10^6 \text{ mm}^3$ )	$\bar{y}$ (mm)	$A\bar{y}$ ( $\times 10^6 \text{ mm}^3$ )	$A\bar{y}^2$ ( $\times 10^6 \text{ mm}^4$ )	I ( $\times 10^6 \text{ mm}^4$ )
①	7.5	437.5	3.281	277.3	2.080	576.7	3.516
②	7.5	250	1.875	89.8	0.6735	60.48	56.25
③	25	50	1.250	-110.2	-2.755	303.6	20.83
	40		6.406		ND ✓	940.8	80.596

$$\bar{y} = \frac{\sum A\bar{y}}{\sum A} = \frac{6.406 \times 10^6}{40 \times 10^3} = 160.2 \text{ mm}$$

$$I = \sum I + \sum A\bar{y}^2 = 80.596 \times 10^6 + 940.8 \times 10^6 = 1021 \times 10^6 \text{ mm}^4$$

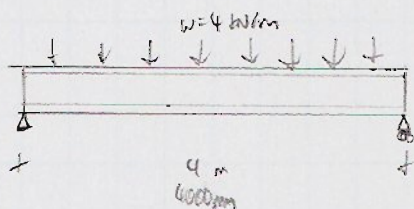

Tensile stress (bottom):

$$\sigma_{\text{tensile}} = \frac{My}{I} = \frac{\left(\frac{4 \times 4000^2}{8}\right)(160.2)}{1021 \times 10^6} = 1.255 \text{ MPa}$$

Compressive stress (top):

$$\sigma_{\text{comp}} = \frac{My}{I} = \frac{\left(\frac{4 \times 4000^2}{8}\right)(314.8)}{1021 \times 10^6} = 2.47 \text{ MPa}$$

The compressive stress is about twice as large as the tensile stress, meaning it is only about 50% efficient. The top flange section could be made larger - either lengthening or thickening it to compensate for the difference in stress.

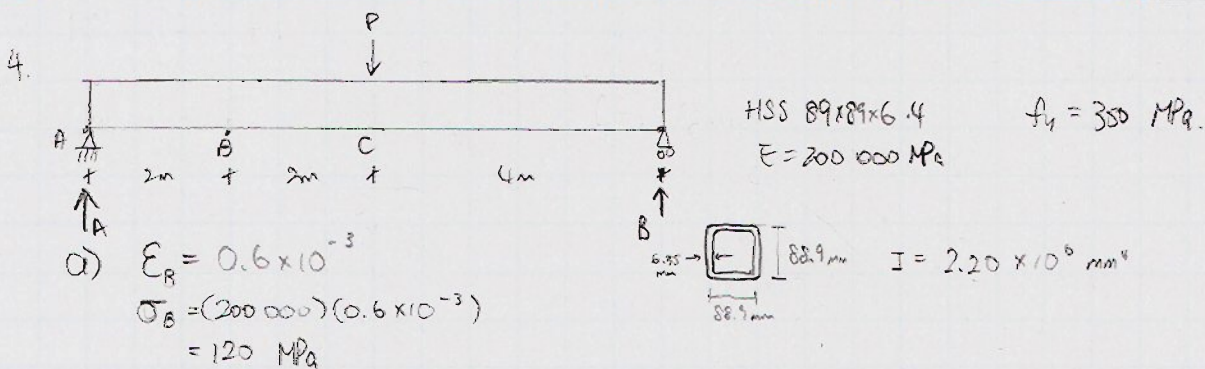

$$\sigma_B = \frac{M_B y}{I}$$

$$120 \text{ MPa} = \frac{M_B \left(\frac{88.9}{2}\right)}{2.20 \times 10^6 \text{ mm}^4}$$

$$M_B = 5.94 \times 10^6 \text{ N}\cdot\text{mm}$$



So, reaction force at A =  $\frac{5.94 \times 10^6 \text{ N}\cdot\text{mm}}{2000 \text{ mm}} = 2.97 \text{ kN}$

$\therefore P = 2(2.97 \text{ kN})$   
 $\therefore P = 5.94 \text{ kN}$

b)  $\sigma_{max,c} = 350 \text{ MPa}$  A.  $P = ?$

$$M_c = \frac{\sigma_c I}{y}$$

$$= \frac{(350 \text{ MPa})(2.20 \times 10^6 \text{ mm}^4)}{\left(\frac{88.9}{2} \text{ mm}\right)}$$

$$= 17.32 \times 10^6 \text{ N}\cdot\text{mm}$$

$$P = 2 \left( \frac{17.32 \times 10^6 \text{ N}\cdot\text{mm}}{4000 \text{ mm}} \right)$$

$\therefore P = 8.66 \text{ kN}$